



# UPDATE

S U M M E R , 2 0 0 3

## PORTAL CRANE PRODUCT SUPPORT TEAM

### Parts

Joey Liverett -  
Portal Parts Specialist  
24-hour line:  
800-633-1136

*Please have the serial number/  
location of crane/part number/  
contact name, phone, fax, and  
address.*

### Service & Training

Ronnie Jones, Service  
Manager  
Birmingham, AL  
(205) 943-5734  
(205) 941-3324 Fax  
24 - hour line:  
(877) 943-5734

### Nu-Life Rebuilt Parts/ Motor Rewinds

Joey Liverett  
Rebuild Coordinator  
(877) or (205) 943-5734

### Product Support Regional Manager

Réal Soucy  
Atlanta, GA  
(678) 665-5225

More Portal Information

[www.portalcranes.com](http://www.portalcranes.com)

## PORTAL CRANE USER MEETING AUGUST 27-28-29, 2003 Birmingham, Alabama – Don't Miss It

The 2003 annual P&H Portal Crane Users Meeting is set for August 27-28-29, and you are strongly encouraged to attend this valuable meeting. You will have the opportunity to discuss and solve many problems that limit your uptime and cost your company significant dollars. Just one problem solved or idea to improve uptime or safety will make your time investment worthwhile. This year we will focus on modernizations and safety issues for maximizing performance of your log crane system.

**See you in Birmingham!**

**REGISTER NOW! SEE INSIDE...**

### FROM THE EDITOR

Dear P&H Portal Crane Customer:

This is the 33rd issue of portal Crane systems **UPDATE** which represents another step in the P&H commitment to serve our customers.

In this and every issue of the **UPDATE**, you will find useful crane service tips, parts and crane modernization information, and other items of interest to portal crane users.

We hope this sharing of knowledge and experience will help you in your efforts to manage your yard efficiently.

Sincerely,

Gary Otto & Chuck Stoneman  
Product Managers  
Portal Crane Products and Services

### 2003 OFF TO A STRONG START

Norbord Nexfor, a manufacturer of wood and wood composite panel products, has awarded P&H/Morris Material Handling a multi-million dollar contract to supply 2 P&H straight track log handling portal cranes.

The cranes will go into service this fall at Norbord's oriented strand board (OSB) plant in Jefferson, Texas. This purchase is a part of their initiative to improve efficiency within their operation. The cranes will dramatically reduce yard operation costs compared to the rubber tired log stackers presently in use. The 155' span, 15-ton lifting capacity cranes store logs in piles up to 65' high using two 65' reach cantilevers and towers more than 100' above the ground.

*see STRONG START on page 2 . . .*

## MODERNIZATION UPDATE

For P&H portal crane owners with span bar type emergency shut-down coupled with the no-festoon dual PLC arrangement, you can now totally eliminate the span bars and upgrade the radio modem link between the PLC's with a low cost upgrade. The change to more modern designed radio links allows elimination of those troublesome bars and collector shoes. The spread spectrum radio link is not susceptible to local radio interference for greater reliability. For a quotation and list of successful installations, contact your P&H representative.

## STRONG START ... CONTINUED FROM PAGE 1

The double crane application eliminates the need for any other form of back-up log feeding equipment and allows maintenance functions to be performed on regular time rather than nights or weekends. This marks a significant change in wood yard design concept from a single one bite unloading crane to two (2) bite cranes.

Norbord stated that the strong P&H product support organization was a key factor in their selection of P&H as its crane supplier for this project. The cranes will be equipped with a long list of the latest technology that will ensure optimum performance and ease of maintenance. Features include: GPS based collision avoidance, load cell type weigh/inventory management, P&H ergonomic cab with long setback, Rockwell PLC's and VFD controls, and off-board diagnostics monitoring through the PLC's, just to mention a few.

## MAINTENANCE TIPS

Remember: If your maintenance tip is featured in the Portal Crane Systems **UPDATE** with a photo, you will receive a portal crane jacket. Ideas only will earn a portal crane T-shirt. Submit your ideas to Gary Otto, and tell us your jacket or shirt size.

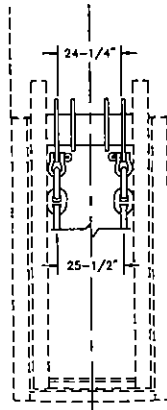

Sharp tine tips result in higher hydraulic pressures needed to dig, shorter grapple life and increased damage to logs.

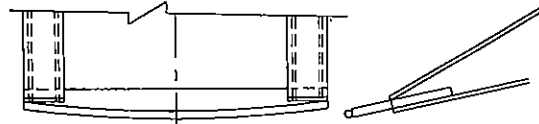

Grapple tines must be blunt and curved using a solid round tip as shown here.

This design reduces closing force and hydraulic pressure required to dig into the pile during retrieval.

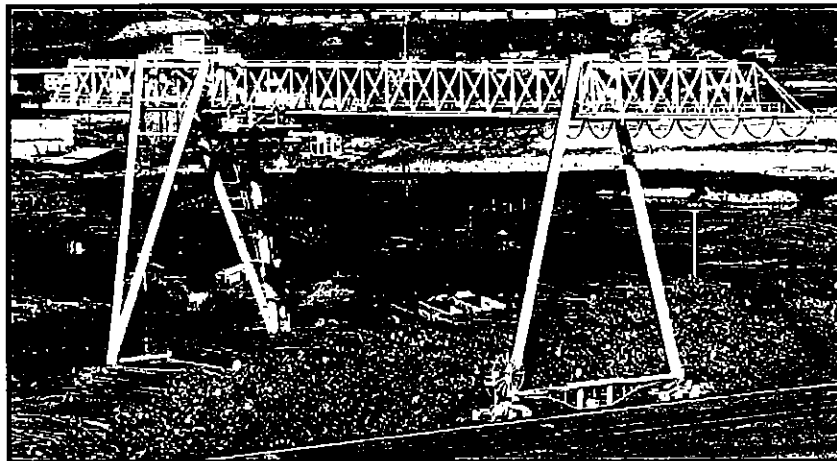
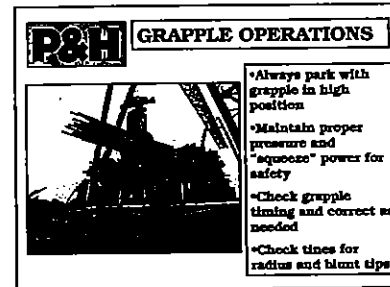
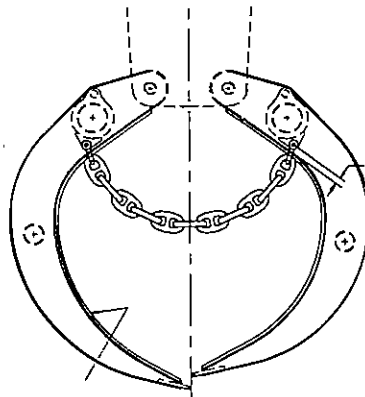

Typical P&H straight track wood yard portal crane.

# MAINTENANCE TIPS (continued . . .)

## SWIVEL TRUCK SERVICE BULLETIN

If your crane is equipped with leg end or bogie swivel devices, regular lubrication must be applied to assure continued proper gantry operation. If the swivel locks up, wheel and rail wear will accelerate.

It is also important to relieve the load on the swivel when greasing. If you have swivel bogies with storm brakes, the process is easy. If not, you must jack your leg end. On swivel bogies you must verify that the swivel thrust washer turns freely and the grease fitting faces outward.

With leg end "cup and saucer" design swivels the side clearances are also critical. A maximum of 60/1000" is allowable.

Wheel alignment is still important with swivel trucks. With bogie swivels, the wheels in each bogie need to be true to each other. With leg end swivels, all wheels on each corner need to be aligned straight.

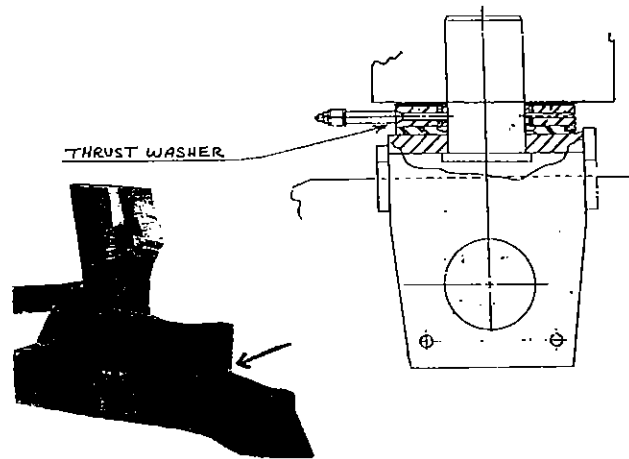

### Keep Your Lifting Beam Level!

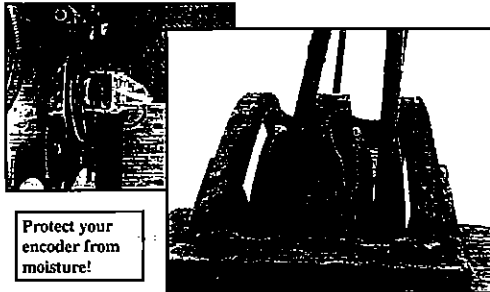

Protect your encoder from moisture!

### All Electric Cable Reels

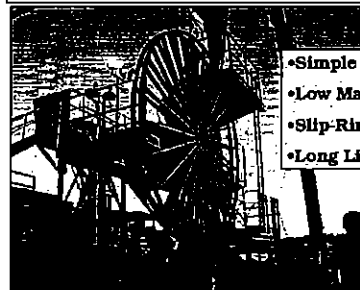

- Simple design
- Low Maintenance
- Slip-Ring Access
- Long Life

### TV Monitors reduce strain and stress on the operator!

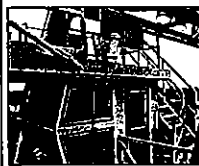

Use multiple cameras  
Try different views!  
Wireless systems



**P&H**

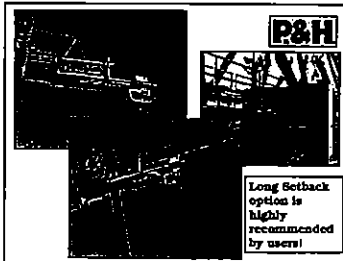

Long Setback option is highly recommended by users!



Simple rope guards can save BIG \$\$\$ on cable damage! Use 1.25" or 1.5" solid rounds.

### Dynamic Storm Brakes offer:



- Risk Control
- Increased Uptime
- Maintenance Aide  
Now available: A limit switch conversion kit to replace the mechanical up/down switch on the brake, with a pressure switch in the powerpack enclosure. Increase reliability!

**P&H**

### Span Bar Replacement & Modem Replacement

The Communicator Module for the SLC A-B PLC



**P&H**

### Grapple PM



- Install doors as shown here
- Keep in 100% condition with regular PM
- Grease at least on a daily basis
- New Lubes now available for greater protection



**2003 MORRIS PORTAL CRANE USER MEETING  
REPLY FORM**

**AUGUST 27, 28, 29, 2003**

ALTA VISTA HOTEL  
260 GOODWIN CREST DRIVE  
BIRMINGHAM, ALABAMA 35209

TOLL FREE: 888-290-8099 or 205-290-8000  
FAX: 205-290-8025

**M E E T I N G   S C H E D U L E**

**WED, AUGUST 27, 2003**

5:30 P.M.-7:00 P.M. REGISTRATION / SOCIAL HOUR

**THU, AUGUST 28, 2003**

7:30 A.M.-4:30 P.M. MEETING / LUNCH  
6:30 P.M.-8:15 P.M. DINNER

**FRI, AUGUST 29, 2003**

7:30 A.M.-11:00 A.M. / MEETING - ADJOURN

COMPANY: \_\_\_\_\_

ADDRESS \_\_\_\_\_

CITY: \_\_\_\_\_ STATE: \_\_\_\_\_ ZIP: \_\_\_\_\_

TEL \_\_\_\_\_ FAX: \_\_\_\_\_

ATTENDEE NAME: \_\_\_\_\_

\_\_\_\_\_

\_\_\_\_\_

\_\_\_\_\_

WHAT ISSUES WOULD YOU LIKE ADDRESSED AT THE MEETING? \_\_\_\_\_

\_\_\_\_\_

\_\_\_\_\_

WHAT SAFETY CONCERNS DO YOU HAVE? \_\_\_\_\_

\_\_\_\_\_

\_\_\_\_\_

**PLEASE FAX REPLY FORM TO: BARBARA KILLINGSWORTH FAX: 205-941-3324 TEL: 800-633-1136  
Morris Material Handling, 117 Lyon Lane, Birmingham, AL 35211**

**BOOK ROOMS DIRECT WITH HOTEL TOLL FREE: 888-290-8099 / FAX: 205-290-8025**

**ROOM RATE:KING / DOUBLE - \$68.99. RATE GUARANTEED UNTIL JULY 5, 2003.**

**NO AIRPORT TRANSPORTATION PROVIDED BY HOTEL. / TAXI IS AVAILABLE.**

## REASONS TO ATTEND THE USER MEETING

There are many reasons for you to attend the user meeting. Here are just a few:

- Learn about the latest crane safety issues
- Get the latest training information
- Meet Portal service personnel
- Learn about crane runways
- Meet people who do what you do
- Find out about the latest technology
- Talk to the grapple experts from Mack
- Learn trouble-shooting techniques
- See various log stacking methods and procedures
- Meet the portal parts personnel
- Share your problems and solutions with others
- Learn how ergonomic cab designs help productivity
- Get lots of maintenance tips and ideas
- Ask lots of questions/get good answers

Those who have attended previous meetings either come back or send other mill personnel the next year. The meeting is attended by woodyard management, maintenance, planing, production, and operator personnel. P&H has service, parts, sales and management personnel present to make your time invested worthwhile.

## COME TO THE 2003 P&H PORTAL CRANE USER MEETING!

## ERGONOMICS - HIGH PRIORITY

Many users are now recognizing the need to improve the workplace environment for their workers. This includes the crane cab, where several effective and affordable ergonomic upgrades can be added to dramatically improve the cab work area.

The replacement of the seat and armchair consoles with the P&H slider base seat and fixed side consoles places the operator closer to his working area and eliminates the unwanted side motions typical of the older rotate seat bearing assemblies. The new configuration allows the operator to position the seat in the optimum location for view of the yard, access to the master switches, and back/shoulder/arm support.

Another improvement is the pivoting front window, allowing easy cleaning access and improved overall vision for the operator. This simple design change made a once difficult task very simple and fast.

Call P&H for a proposal for improving your crane's ergonomics.

## WHEEL DEAL !!!

Joey Liverett just "rolled out" another real wheel deal that can save money! Purchase four or more gantry or trolley wheels and earn an extra 10% discount on the total order value. This offer is good from June through Sept. 30, 2003. Call Joey at 800-633-1136

## HURRICANE SEASON UPDATE:

As the hurricane and strong thunderstorm season approaches, take precautions to avoid wind damage to your crane. Keeping your tracks clean, brakes in 100% condition and your tie-downs ready to go is the minimum that should be done. P&H Storm brakes are also a plus for protection. Don't park your crane with the grapple anchored in the pile, but rather pull it up to high position, since a lightning strike could ground through the cables and weld the strands together, thus destroying the wire ropes, or if blown out of position, the grapple could drag over equipment causing damage. Monitor local conditions and be prepared.

## RÉAL SOUCY JOINS P&H PORTAL CRANE SUPPORT TEAM

Please join us in welcoming Réal Soucy (pronounced Ray-Al Sue-See) to the Morris Material Handling Organization.

On June 9, Mr. Soucy joined the P&H Portal Crane Team as the P&H Portal Crane Southeast Regional Sales Manager. He is a technical professional with over 20 years of experience with cranes and material handling in the Pulp and Paper, OSB and Wood industries. Réal is experienced in technical sales, project management and has a solid background in industrial design.

Réal will be active with product support including parts, service, inspections, training and PM programs plus any future new crane equipment projects or any projects requiring the modernization of your existing cranes. He has a proven track record of delivering customer satisfaction while managing the complete project. His field experienced combined into our very successful Portal Crane Team make P&H the best choice for supporting all your material handling needs.

Do not hesitate to call Réal, in Atlanta, at (678) 665-5225 to help with your service, parts or future crane modernizations and up-grades. He will be delighted to help you in reducing your operating costs while increasing your crane up-time performance.



## TRAINING UPDATE

The P&H/Morris Institute offers both in-house and on-site training for electrical, mechanical, and most control types as well as operator training for all types of cranes. A simulator has now been developed for overhead crane training, and the Institute utilizes the latest training technology to add value to your training investment.

### ADVANCED OPERATING TRAINING

P&H Morris continues to provide advanced operating training for all types of log handling cranes. References will confirm the outstanding value of this unique product support service. Contact Chuck Stoneman or Ronnie Jones to find out how advanced operator training can enhance your woodyard operations.

## WWW.PORTALCRANES.COM GOES ON-LINE

The new P&H Portal Crane web page can now be viewed by simply going direct to [www.portalcranes.com](http://www.portalcranes.com). Find the latest in product news, Update newsletter index, all back UPDATE issues, product support information and case studies.

P&H Portal Crane Web Site:

[www.portalcranes.com](http://www.portalcranes.com)

## CWF/TAPPI PORTAL CRANE USER GROUP UPDATE

The CWF-TAPPI Log Crane User Meeting was held April 7-11, in Panama City, FL. The 4 day event featured presentations from a wide variety of suppliers and users on a broad range of portal crane topics. All of the presentations can be downloaded from the User Website shown below, as well as the plans for next year's meeting.

Portal User Group Web Site:

[www.craneusers.org](http://www.craneusers.org)

## P&H INSTITUTE CLASSES

1. Smartorque AFD VG+ & G+ Series 2, July 15-18, 2003
2. Overhead Crane Mech. Maint. July 22-25, 2003
3. Overhead Crane Inspection July 29-Aug. 1, 2003
4. Static Stepless Class Aug. 5-8, 2003
5. Static Stepless Lab Aug. 11-14, 2003

Call The Institute at 262-821-4006 for more information.

## WE DO ON-SITE CLASSES TOO!

### MOTAG SOUTH AUGUST 6-7-8, 2003

MOTAG South will hold its 2003 summer session in Atlanta, GA. The meeting opens with a social hour on Wednesday evening and generally has attendance over 150, with a focus on woodyard and chipping operations.

MOTAG is short for "Millyard Operators' Technical Advancement Group." You can register at the meeting by going directly to the Renaissance Concourse Hotel by the Atlanta Airport or visit the website at [www.motag.org](http://www.motag.org) for lots of MOTAG info.

## 14TH ANNUAL P&H PORTAL CRANE USERS MEETING AUG. 27-28-29, 2003

PLAN TO  
ATTEND



Morris Material Handling, LLC  
315 West Forest Hill Avenue  
Oak Creek, WI 53154 USA  
Telephone: 262-821-4020  
Facsimile: 262-641-9206  
Internet: [www.morriscranes.com](http://www.morriscranes.com)  
Gary Otto: Cell: 414-573-8062  
gotto@morriscranes.com  
Chuck Stoneman: (604) 931-1182  
Cell: 604-3115-4355  
cstoneman@morriscranes.com

© Morris Material Handling, LLC,  
All rights reserved.



## LOG HANDLING PORTAL CRANES

- ISO 9001 Quality
- High Availability
- Excellent Service
- Proven Performance
- Reduced Log Breakage



- Straight Track
- Rotating Portal
- Log Boom
- Modernizations



[www.morriscranes.com](http://www.morriscranes.com)  
1-800-933-2313